

# HB40HP

## EXTERIOR LINEAR LED LIGHTBAR

Date: | Firm: | Project: | Contact:

24VDC 689lm/ft. 10.42w/ft.

### APPLICATION

A powerful, linear exterior architectural high-performance LED luminaire designed for Wall Washing, Grazing, Cove and Flood applications. Ideal for illumination between 15 and 35 feet depending on optics. Cool running LEDs ensure long life.

The HB40HP 24v used an external 24VDC power supply. Available in five lengths and many color temperatures. Nichia Bin sorted LEDs produce high quality illumination sought after by architects and lighting designers. Our optical lenses are designed to produce more light using less power to achieve the desired effect. Fixtures are constructed with an extruded anodized aluminum housing with tooled end caps. The LTW connectors provide a secure IP66 rated connection. Choose from a variety of mounting options.

### FEATURES

- UL Listed
- Certified to CSA Standard
- Low-wattage, low voltage, very low heat operation
- User friendly, easy installation with top quality connectors
- Stainless Steel Flat or Adjustable bracket mounting
- Optional Extrusions, Mounting Arms, and Louvers

### PHYSICAL

<b>Housing</b>	Extruded Anodized Aluminum Housing
<b>Fixture Lengths</b>	10", 19", 28", 37" & 46"
<b>LEDs per foot</b>	8 LEDs per foot
<b>Optics</b>	15°, 20°, 30°, 45°, 120°, 13°x17°, 30°x60°
<b>Lens</b>	Frosted Flat Polycarbonate Lens
<b>Connection</b>	Bottom Wire/Connector Feed
<b>Hardware</b>	Stainless steel flat or adjustable brackets
<b>Environment</b>	IP66 Wet Locations, 0-100% non-condensing humidity

### WARRANTY

Our fixtures are backed by a 5-year limited warranty



### ELECTRICAL

<b>Input Voltage</b>	24VDC
<b>Driver</b>	External driver
<b>Fixture wattage</b>	10.42w/ft.
<b>System wattage</b>	9.48w/ft.
<b>Cable</b>	PVC 2C 20 AWG.
<b>Dimming</b>	0-10v
<b>Lumens per watt</b>	73 lm/w
<b>Max Run Length</b>	10ft.@24VDC, 96w max run length

### PERFORMANCE

<b>Color Options</b>	28k, 30k, 35k, 41k, 50k, 65k, Red, Blue, Green
<b>Lumen Output</b>	689lm/ft.
<b>Operating Temps</b>	-40°F to 122°F, (-40°C to +50°C)
<b>CRI</b>	83 or 94
<b>LEDs</b>	Nichia LEDs

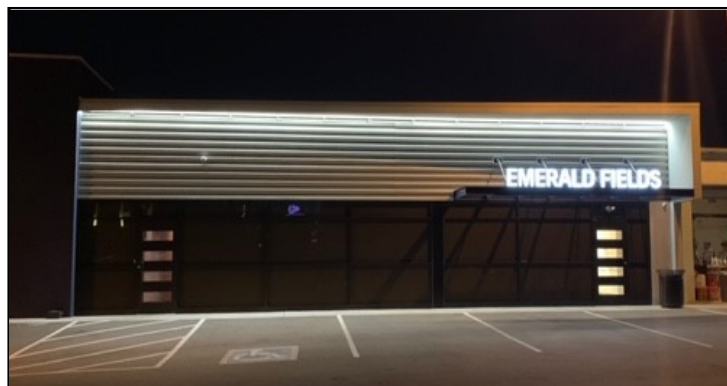

For more information visit us at...  
[thesmartlightingcompany.com](http://thesmartlightingcompany.com)

or call 949-346-3456

1731 Kaiser Ave. Irvine, CA 92614



## CREATE YOUR PART NUMBER HERE

MODEL	LENGTH	COLOR	OPTICS	VOLTAGE / DIMMING
HB40HP	10" 10 inch	<b>WHITE</b>	<b>MONO</b>	24VDC
	19" 19 inch	28k 2800k	RED Red	
	28" 28 inch	30k 3000k	BLU Blue	
	37" 37 inch	35k 3500k	GRN Green	
	46" 46 inch	41k 4100k		
		50k 5000k		
	65k 6500k			
			15 15° beam	
			20 20° beam	
			30 30° beam	
			45 45° beam	
			120 120° beam	
			1317 13°x17° beam	
			3060 30°x60° beam	

## ACCESSORIES

### WIRE LEADS

### 1 WIRE LEAD AND END CAP REQUIRED FOR EACH RUN

_____ AL-HB2P-LTW-72"FE-W/L	72" (6ft) Starter Cable
_____ AL-HB2P-LTW-xx"FE- W/L	xx" (CU) Starter Cable (custom length - consult factory)

### JUMPER CABLES

_____ AL-HB2P-LTW-12"-J	12" (1ft) Jumper Cable
_____ AL-HB2P-LTW-72"-J	72" (6ft) Jumper Cable
_____ AL-HB2P-LTW-xx"-J	xx" (CU) Jumper Cable (custom length - consult factory)

### END CAP

_____ AL-HB2P-END CAP	END CAP
-----------------------	---------

### MOUNTING HARDWARE

### 2 MOUNTING BRACKETS REQUIRED PER FIXTURE

_____ AL-HB40 ADJ.BRACKET	HB40 Adjustable bracket
_____ AL-HB40-FLAT BRACKET	HBO Flat bracket

### 0-10v DIMMER SWITCH

_____ IP710-DLZ	0-10V Dimmer
-----------------	--------------

### GLARE PROTECTION

_____ HB40-10" LOUVER	10" Louver
_____ HB40-19" LOUVER	19" Louver
_____ HB40-28" LOUVER	28" Louver
_____ HB40-37" LOUVER	37" Louver
_____ HB40-46" LOUVER	46" Louver

## MOUNTING OPTIONS

HOUSING AND EXTENDED ARMS (Fill in Quantity, then select housing length, paint color and extended arm length)  
 Finish options - BK-BLACK, BR-BRONZE, CU-CUSTOM

QTY HB40EXT-XXL-XXF-XXA (L=Length, F=Finish, A= Extended arm length)

_____ HB40EXT-10"	10" housing with extended arms
_____ HB40EXT-19"	19" housing with extended arms
_____ HB40EXT-28"	28" housing with extended arms
_____ HB40EXT-37"	37" housing with extended arms
_____ HB40EXT-46"	46" housing with extended arms
_____ HBEXP-GPS	Ground post stakes

## OPTICS

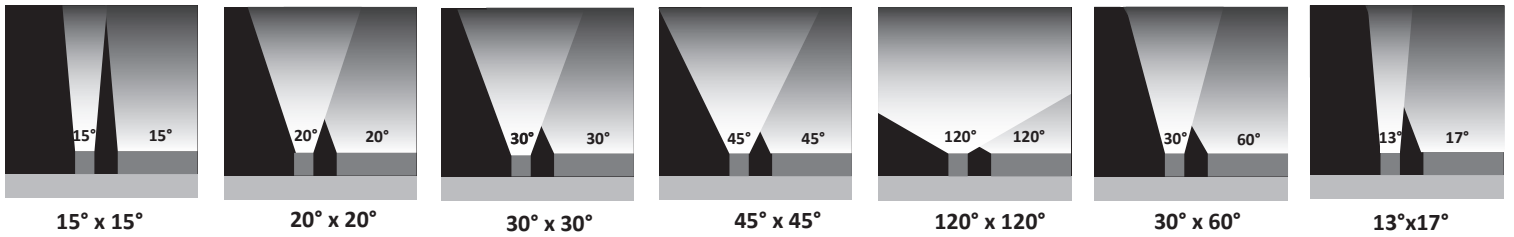

## COLOR TEMPERATURES

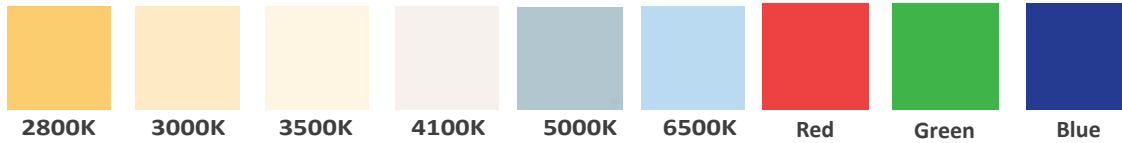

## DIMENSIONS AND DATA

MODEL NUMBER	VOLTAGE	VIEW ANGLE	WATTS/FIXTURE	LUMENS/FIXTURE	LEDS/UNIT	EXTRUSION LENGTH (A)	TOTAL LENGTH (B)
HB40HP-10-XXK-XXD-24V	24VDC	15°, 20°	8.6	574 lm	6	9.35" (237.4mm)	10" (256mm)
HB40HP-19-XXK-XXD-24V		30°, 45°	16.5	1091 lm	12	18.32" (465.4mm)	19" (484mm)
HB40HP-28-XXK-XXD-24V		120°	24.31	1608 lm	18	27.30" (693.4mm)	28" (712mm)
HB40HP-37-XXK-XXD-24V		13°x17°	32.12	2126 lm	24	36.28" (921.4mm)	37" (940mm)
HB40HP-46-XXK-XXD-24V		30°x60°	39.94	2643.2 lm	30	45.25" (1149.4mm)	46" (1168mm)

## PROFILE

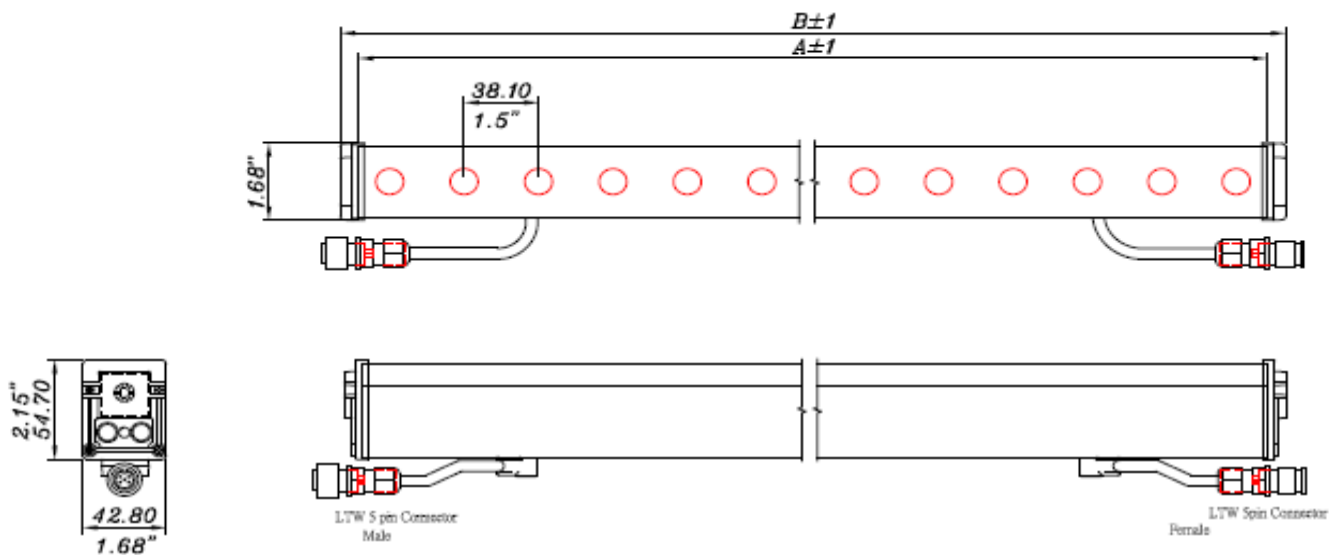

Date:

Firm:

Project:

Contact:

## WIRE LEADS

AL-HB2P-LTW-xx"FE- W/L ..... 2 pin wire

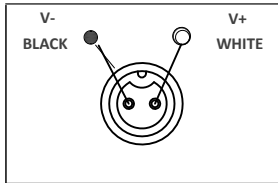
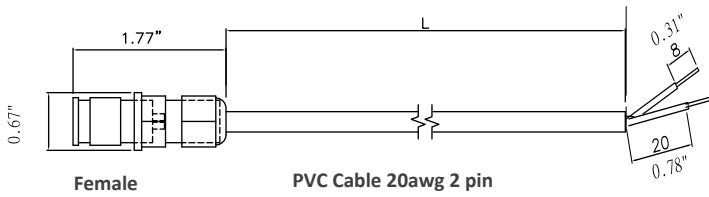

## JUMPER CABLES

AL-HB2P-LTW-xx"FE- J .....2 pin jumper

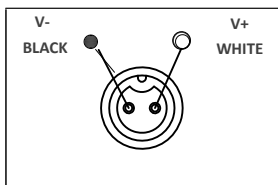
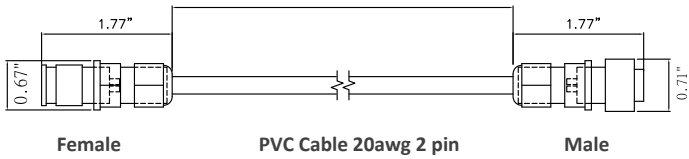

Date: | Firm: | Project: | Contact:

## ADJUSTABLE BRACKETS

DESCRIPTION	PART NUMBER
HB40 ADJUSTABLE BRACKET.....	AL-HB40 ADJ.BRACKET

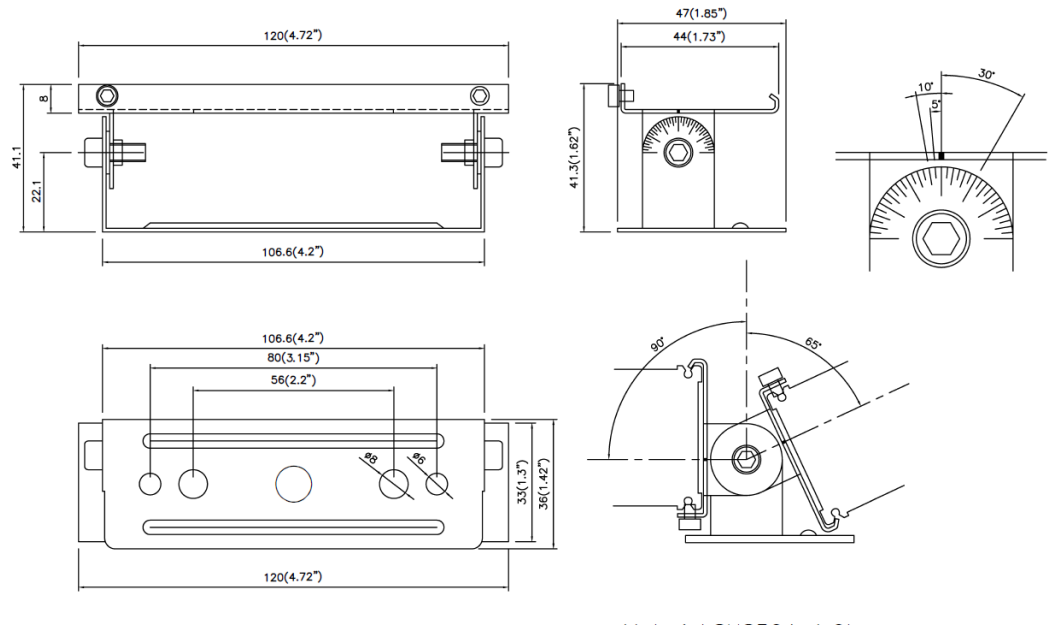
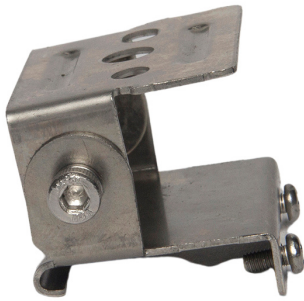

## FLAT BRACKETS

DESCRIPTION	PART NUMBER
HB40 FLAT BRACKET.....	AL-HB40-FLAT BRACKET

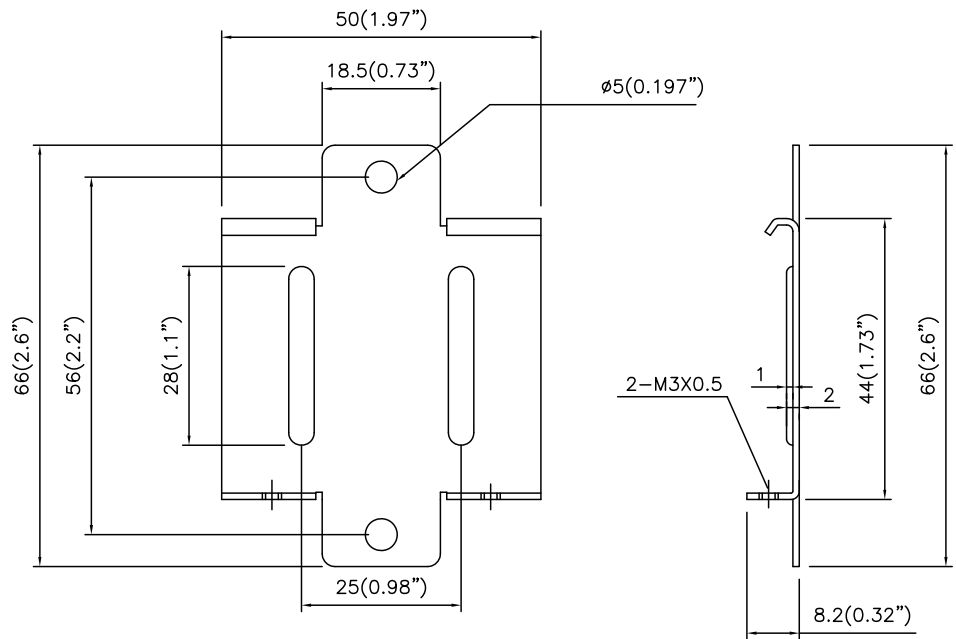

Date: \_\_\_\_\_ Firm: \_\_\_\_\_ Project: \_\_\_\_\_ Contact: \_\_\_\_\_

## LOUVERS

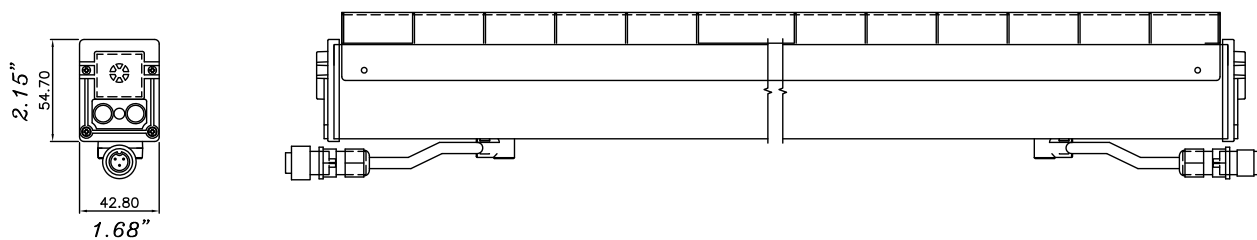
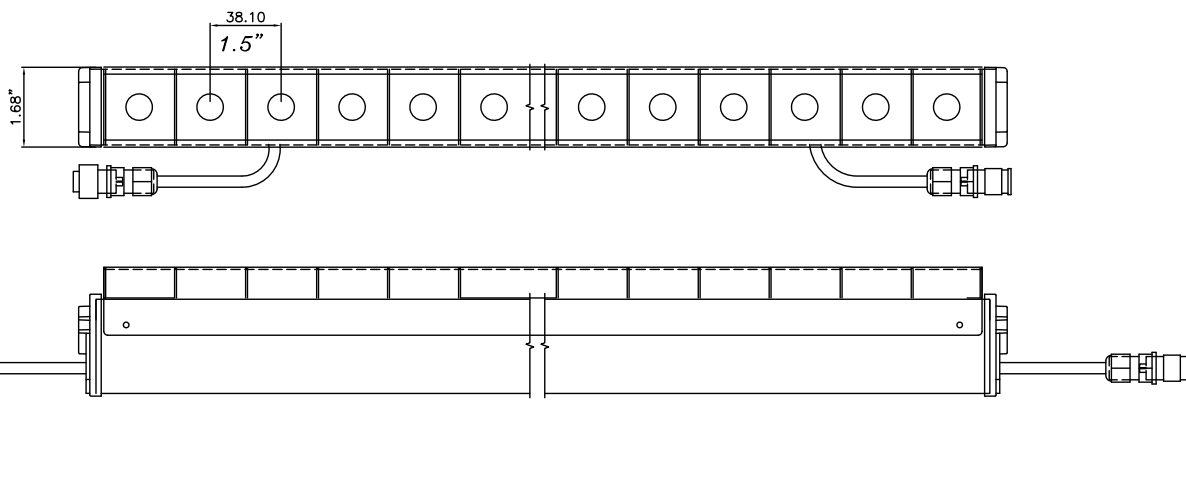
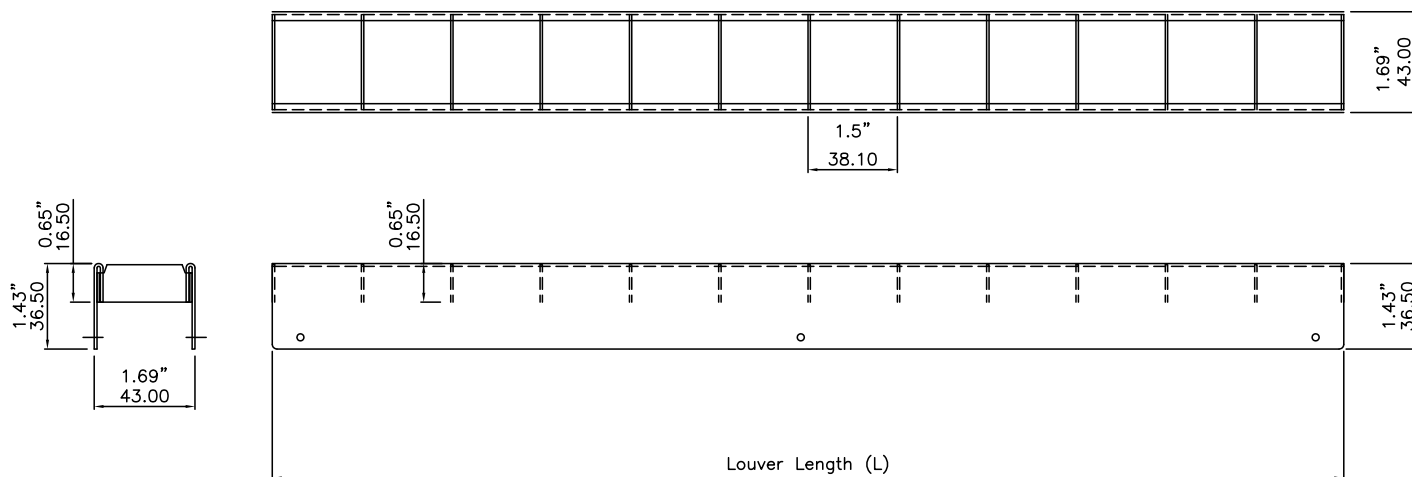

Date:

Firm:

Project:

Contact:

## EXTRUSIONS AND EXTENDED ARMS

HB40EXT-XXL-XXF-XXA (L=Length, F=Finish, A= Extended arm length)

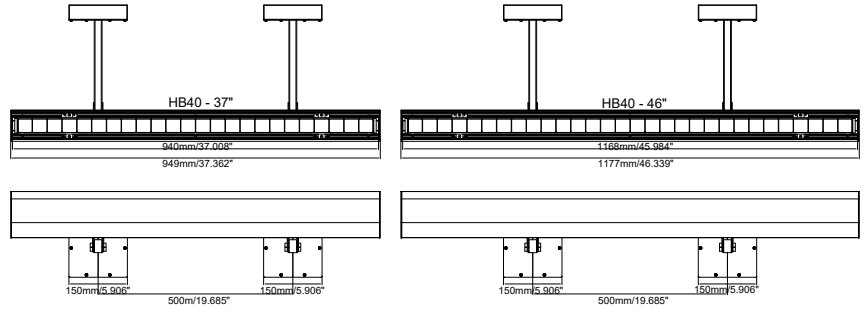
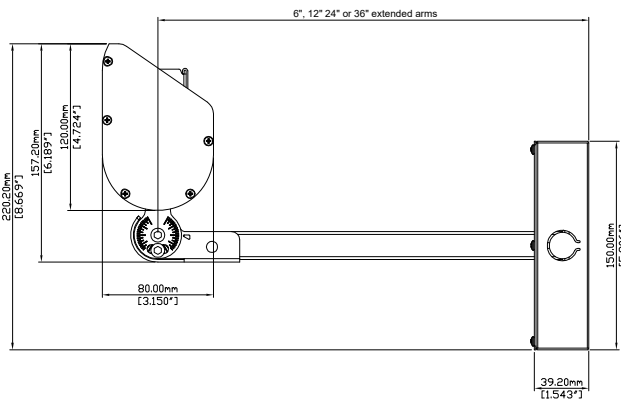
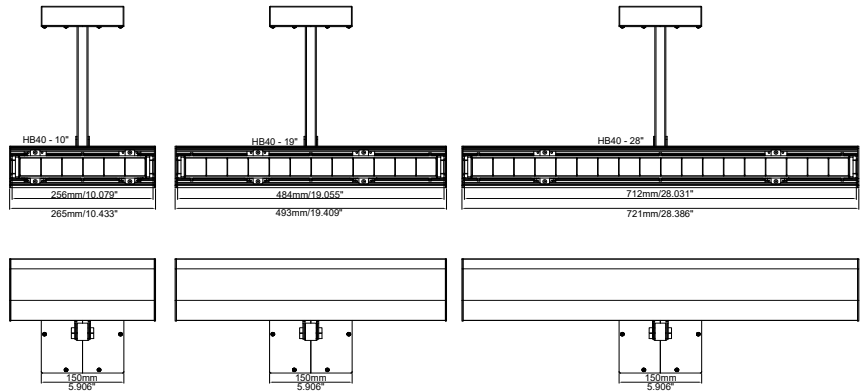

## GROUND POST STAKES

HBEXP-GPSS

